

Fire Station
FS1020

Installation, Maintenance,
and Operation Manual

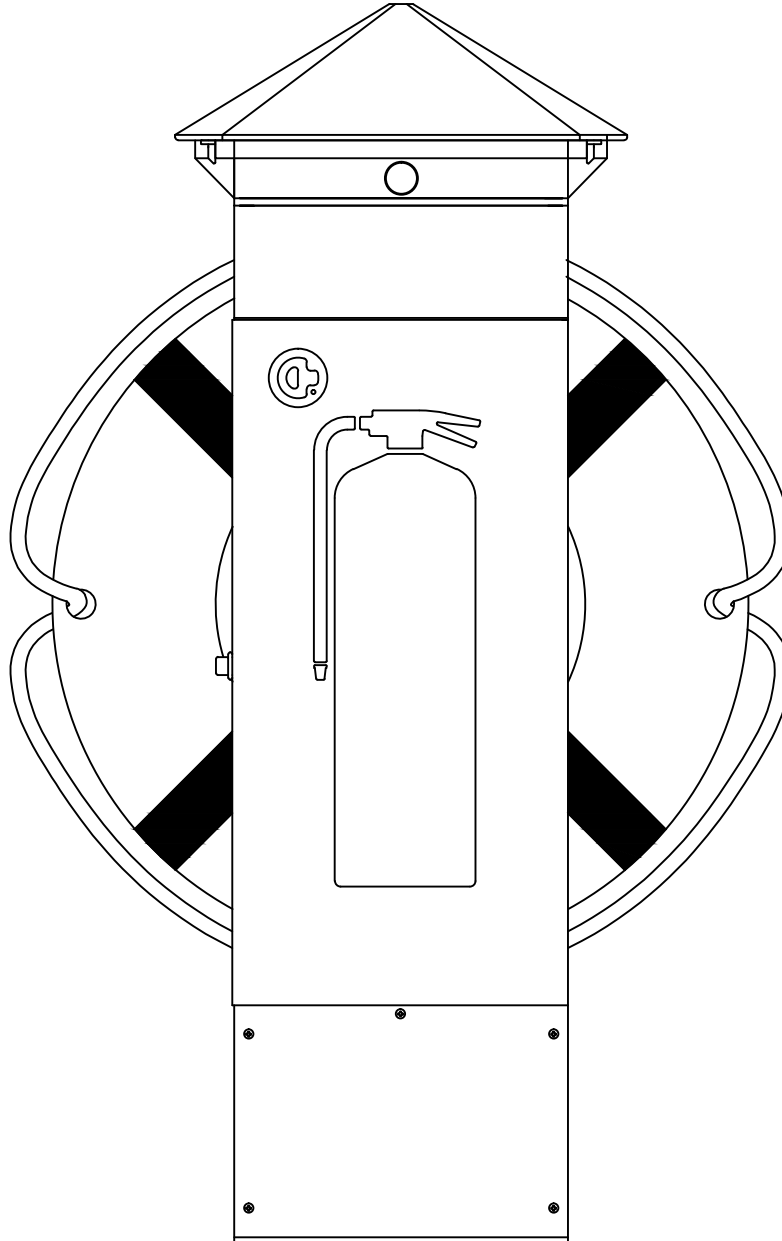

Marina Electrical Equipment, Inc.
1715 Merrimac Trail
Williamsburg, VA 23185
Toll Free: 1-855-258-3939
Fax: 1-757-258-3988



Intertek

4005786

CONFORMS TO STD. ANSI/UL2017

Fire Station FS1020

Installation, Maintenance, and Operation Manual

INTRODUCTION:

PRODUCT DESCRIPTION:

The "Fire Station" pedestal is designed to comply with NFPA 303 as a weatherproof enclosure to house a 10 or 20-pound type ABC fire extinguisher and/or 24" throw-able life ring.

WARNING: Disconnect power before servicing. Marina Electrical Equipment, Inc. recommends that only qualified personnel or an electrician, familiar with the operation of this power outlet equipment, should install or service this power outlet. This product must be installed in accordance with the National Electrical Code (NEC) or the Canadian Standards Association (CSA) and any other applicable local codes. Before installing equipment, check with your local electrical inspector for specific requirements and information for your area.

NOTE: ELECTRICAL CONNECTIONS PER NEC 555.9 - All electrical connections shall be located at least 12 inches above the deck of a floating pier, but not below the electrical datum plane.

CAUTION: Marina Electrical Equipment, Inc. will not assume any responsibility for property damage or personal injury resulting from misuse of the information in this manual.

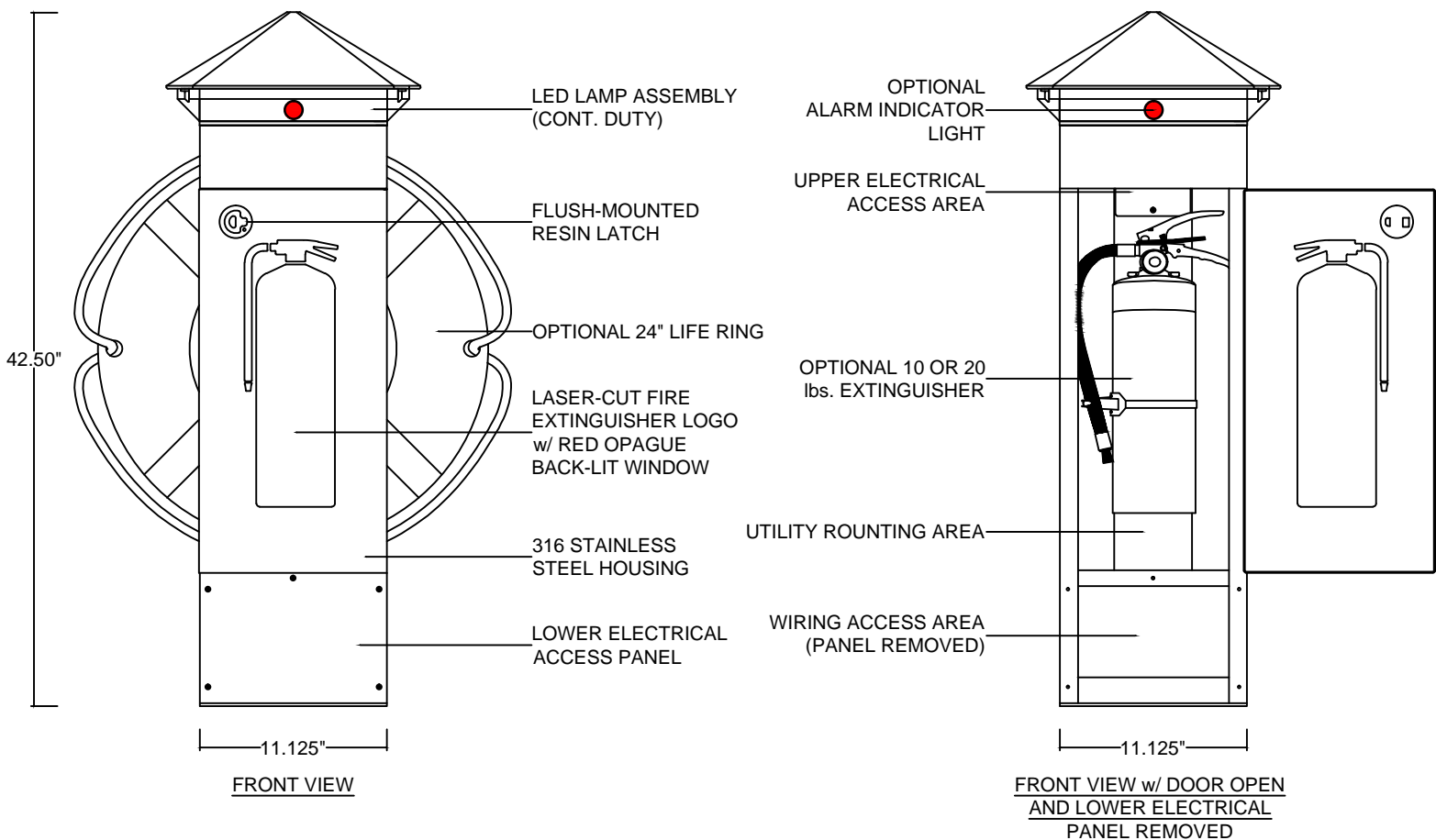

Fire Station FS1020

Installation, Maintenance, and Operation Manual

INSTALLATION:

IMPORTANT: The Fire Station is thoroughly painted on the bottom and the mounting base plate is specially designed to protect the bottom of the pedestal from direct contact with the dock surface to inhibit the corrosive effects of treated deck board lumber and/or concrete. Please handle the pedestal with care while mounting so as not to scrape or damage the paint on the bottom, which could lead to corrosion problems and a cancellation of the factory warranty.

Step 1: Securing the Base Plate to Mount the Fire Station:

Note: The pedestal mounting surface must be flat and level for proper mounting. Warped decking or uneven concrete surfaces can be shimmed with stainless steel washers to provide a level surface for mounting base installation.

On Wooden Docks: At each corner, fit the mounting base plate to the dock surface with one (1) 3/8" stainless steel bolt and washer for through-bolting, or (1) 3/8" stainless steel lag bolt and washer for surface mounting.

On Concrete Docks: At each corner, fit the mounting base plate to the dock surface with one (1) 3/8" stainless steel compression bolt or 3/8" stainless steel threaded rod cast in concrete on 8-1/4" centers.

Step 2: Mounting the Fire Station:

After the mounting base has been installed, orient the "Fire Station" so that the fire extinguisher access door is accessible from the dock walkway. Place the "Fire Station" over the mounting base and secure with the included six (6) #10 X 3/4" stainless steel machine screws and washers (see figure below).

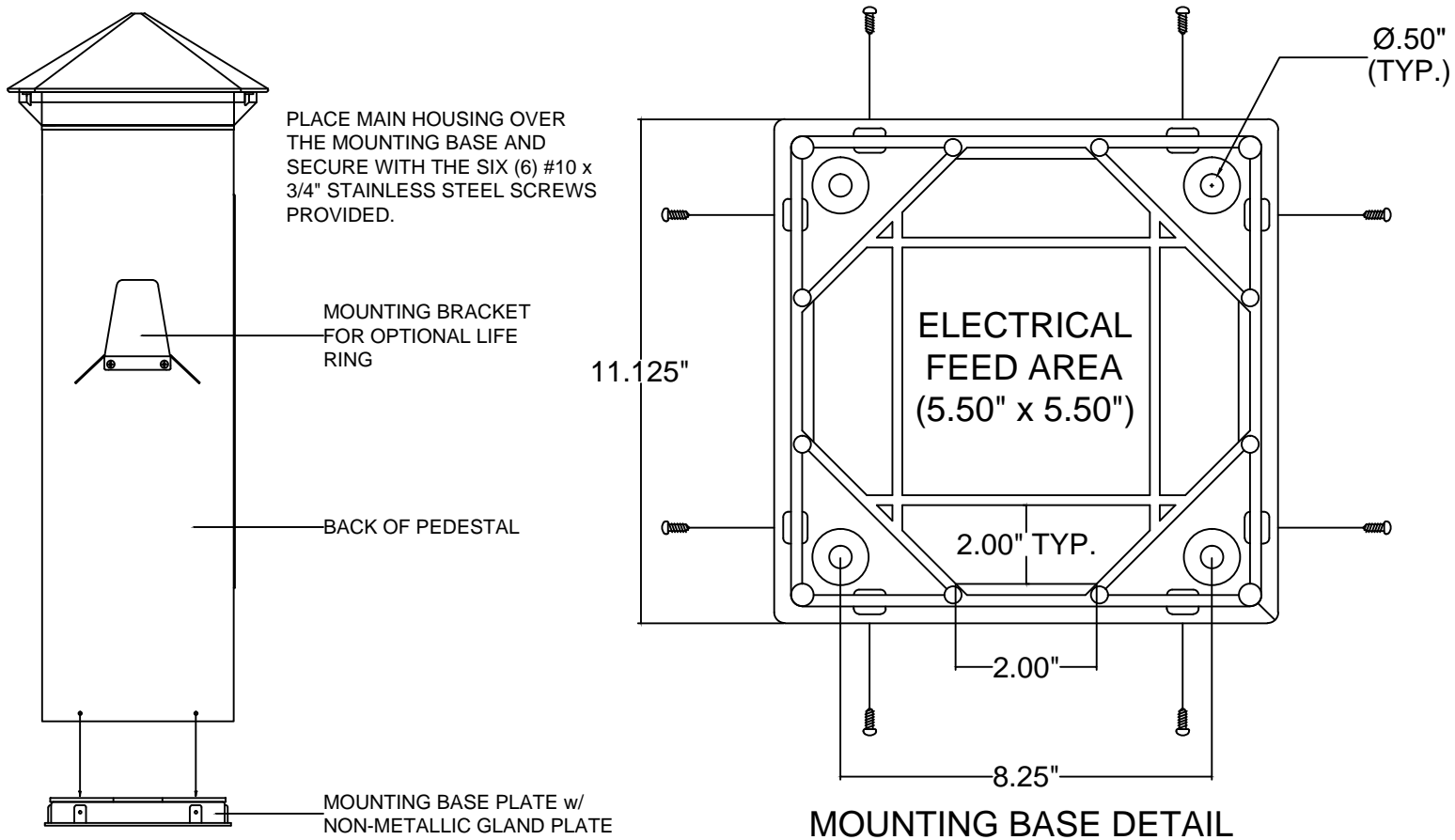

Fire Station FS1020

Installation, Maintenance, and Operation Manual

Step 3: Connecting the Power Lines to the Terminal Block:

The "Fire Station" safety pedestal contains a terminal block within the top lens tray. Simply remove the five (5) screws holding the bottom access panel and the four (4) screws holding the pedestal top, and feed the line wires through the back utility routing channel up to the lens tray (see figure below). Another access panel is provided at the top of the channel to assist in the routing of the wires (see figure below). Feed the wires through the 5/8" access hole and make the appropriate terminations on the labeled terminal block (see figure below).

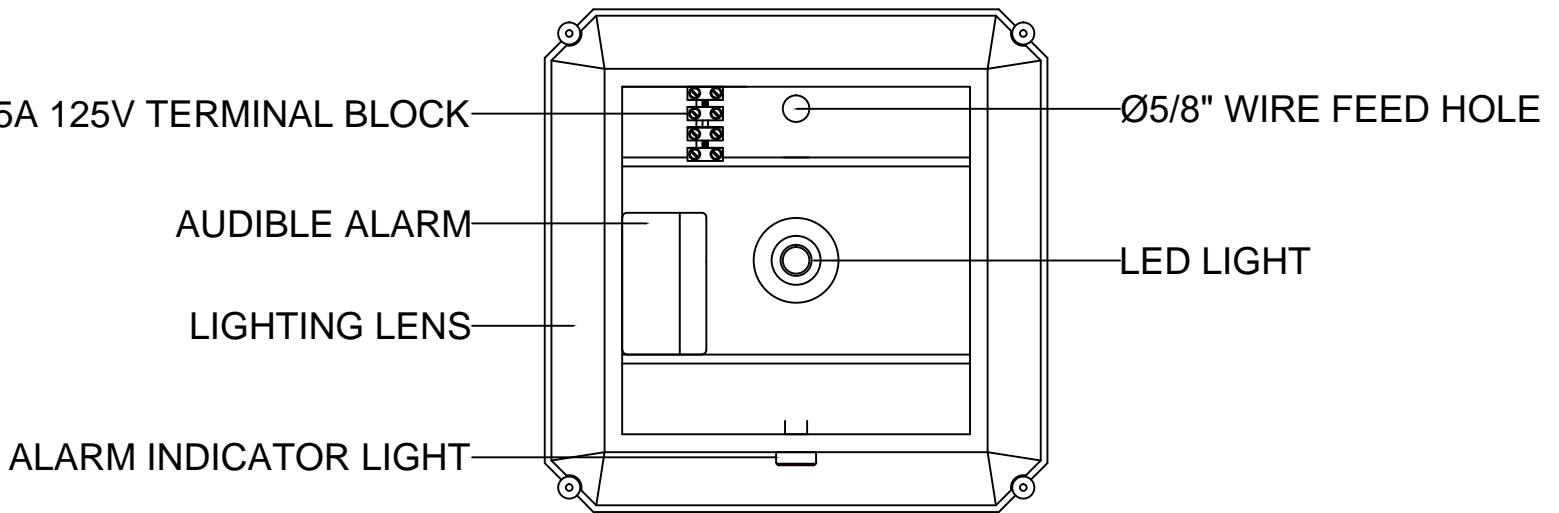

ARIEL VIEW w/ POLYCARBONATE
TOP REMOVED

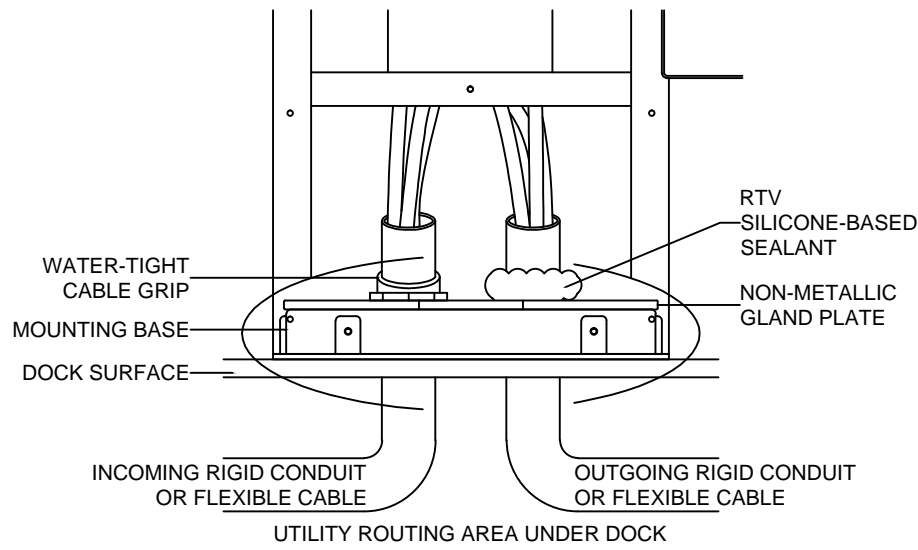

BASE ENTRY DETAIL

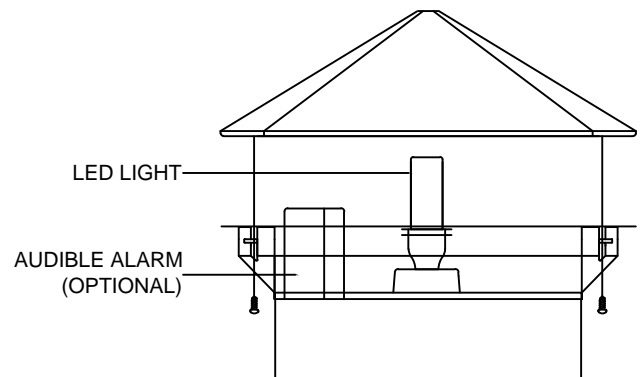

FRONT VIEW w/ TOP
REMOVED

Fire Station FS1020

Installation, Maintenance, and Operation Manual

EXTERIOR MAINTENANCE:

Dirt, grime, bird droppings and insect residue can be removed by use of a mild degreasing solution mixture of one teaspoon per gallon of warm water. Gently scrub the housing exterior and rinse clean. Spiders and other insects can be controlled by use of a **WATER-BASED** insect spray.

WARNING: DO NOT use any petroleum or solvent-based insect spray or corrosion inhibiting products on any part of the power pedestal. These solvents will compromise the structural integrity of the polycarbonate material and cause stress cracking and material failure. Use of any such solvents will void the manufacturer's warranty.

TOUCHING UP DAMAGED POWDER COAT

- 1) Scuff the area well with wet and dry 220-grit sandpaper.
- 2) Clean the area (dishwashing detergent and water) and allow to dry.
- 3) Shake the touch-up powder paint can vigorously for two to three minutes each time you are going to use it to paint.
- 4) Apply the paint in thin coats until you achieve the correct darkness of color. Apply the paint at approximately 8 inches from the surface. Allow each coat of paint to dry for at least 30 minutes before applying another coat. In most cases you can reach the desired color in three coats of paint. In rare cases you might require more than three coats of paint; if this is the case let the final coat dry for at least 24 hours before touching the surface.

INTERIOR MAINTENANCE:

WARNING: Turn off or disconnect the power supplying this equipment before beginning work. This might require you to contact your local utility to disconnect the power to an existing panel board or disconnect. The line side of the main breaker in a panel board is energized unless power is disconnected upstream. Marina Electrical Equipment, Inc. will not assume any responsibility for property damage or personal injury resulting from misuse of the information in this manual.

1. Annual Test:

Annually, test the alarm/strobe device for proper functionality. Simply open the extinguisher access door and lift the life ring off of its bracket. Both of these actions should trip the alarm/strobe device. Replace defective parts as necessary.

2. Check Fire Extinguisher Charge:

Monthly, check the extinguisher charge to see that it is full. Replace as necessary.

3. Annual Light Fixture Maintenance:

The light fixture is continuous duty. Should the bulb not illuminate, unscrew the four (4) screws underneath the top to remove the top and expose the lamp holder and bulb. Check the 5A protective inline fuse and replace if necessary. Replace the bulb and re-fasten the top.

END OF SECTION

Specifications Subject to Change Without Notice

Fire Station FS1020

Installation, Maintenance, and Operation Manual

WARRANTY POLICY

WARRANTY POLICY

Housings:

Marina Electrical Equipment, Inc. (MEE) warrants that the main housing and attached parts (top, lens, doors, receptacle faceplates, circuit breaker plates, and mounting base plate) will be free from failure resulting from defects in material and/or workmanship, and are covered by a limited warranty of one (1) year. Should any of the above parts fail to comply with the above-mentioned warranty, MEE will either repair or replace the defective part(s), or credit the purchaser for the purchase price of the part. This warranty is voided if any petroleum-based solvent is used anywhere on or near any of the polycarbonate parts. These parts include, but may not be limited to: the top, lens, doors, receptacle faceplates, circuit breaker plates, terminal block, and the mounting base plate.

Internal Components:

MEE warrants that all internal electrical components shall be covered by a limited warranty of one (1) year. Items covered include: receptacles, circuit breakers, photocells, lamp holders, coil transformers, counters and wiring harnesses. Should any of the above parts fail to comply with this warranty policy, MEE will coordinate the repair or replacement of the defective part(s) with the respective supplier.

Solid-State Electric kWh Monitors:

MEE warrants that the International Intelligent Meter (IIM) solid-state electric kWh monitors will be free from failure resulting from defects in material and/or workmanship, and are covered for one (1) year. Although the IIM meters contain integrated surge protection, MEE and IIM will not warrant the product against severe over-voltage conditions such as lightning strikes or abnormal utility surges. Should an electric monitor fail to comply with the above-mentioned warranty, MEE will either repair or replace the defective part(s)/components, or credit the purchaser for the purchase price of the part. This warranty is voided if the damage to any or all of the components is the result of abuse, misuse, or Force Majeure. This warranty is voided if the factory seal is broken or manipulated.

This warranty policy does not cover damage or failure resulting from abuse, misuse, negligence or Force Majeure. All warranty claims must be made in writing and all defective products shall be returned to MEE for evaluation unless stated otherwise by MEE. MEE will not be responsible for reimbursing the purchaser for any sort of expense incurred by the purchaser as a result of the repair or replacement of a warranty claim.

Send all warranty claims to:

Marina Electrical Equipment, Inc.
1715 Merrimac Trail
Williamsburg, VA 23185
Toll Free: 1-855-258-3939
Fax: 757-258-3988

Specifications Subject to Change Without Notice

END OF SECTION